

¹Laser and Plasma Research Institute, Shahid Beheshti University, and ²School of Medicine, Shahid Beheshti University of Medical Sciences, Tehran, Iran

Surface Decontamination by Dielectric Barrier Discharge Plasma

Ghomi H.¹, Mohades S.^{1*},
Navab Safa N.¹, Dabiri H.²

Abstract:

Background: Dielectric barrier discharge (DBD), a source of non-thermal plasma, is used in surface decontamination.

Objective: To study the effect of DBD plasma treatment, we evaluated the effect of plasma exposure time on inactivation of *Bacillus subtilis*.

Results: Applying the DBD plasma to the culture of *B. subtilis* caused complete sterilization of the surface without any thermal effects. In addition, the inactivated colony-forming units increased as the exposure time rises.

Conclusion: Considering the low temperature and non-destructive features of this method, it seems that this method is applicable for fast sterilization of resistant bacteria and hospital sensitive instruments.

Keywords

Bacillus subtilis; biomedical; cold plasma; dielectric barrier discharge; microbial inactivation.

Introduction

Plasma is the fourth state of matter and exists in thermal and non-thermal forms. Dielectric barrier discharge (DBD) is a typical non-thermal and high-pressure ac gas discharge [1, 2]. For its properties, it is found suitable for many chemical and medical applications. Some of its applications are ozone production, surface treatment, high-power CO₂ lasers, pollution control, *etc* [3]. Recently, DBD, due to its low temperature and atmospheric working pressure, draws attentions of many researches to use it for sterilization and surface decontamination.

All traditional methods, such as heat, radiation, and physical or chemical methods of sterilization, have many drawbacks that limit their use in treatment of heat sensitive and vulnerable objects such as organic materials, foams, liquids, and living biological tissues [4, 5].

Autoclaving, as a prevailing method, works at two situations: dry heat of 160 °C for two hours and steam heat of 121 °C with a pressure of 15 PSI for 10 to 15 minutes. Obviously, autoclaving is destructive to heat sensitive materials and those that are vulnerable to high pressure; moreover, it is a time consuming method [6].

Ultraviolet (UV) light in the wavelength range of 240 to 280 nm, is used for decontamination of laboratory instruments. However, its usage is limited by its penetration and for safety reasons; furthermore, this method needs long time of radiation [6, 7]. Other methods include use of chemical substances (*e.g.*, H₂O₂ and ethylene oxide) that produce some

*Corresponding author:
Soheila Mohades,
Laser and Plasma Research Institute,
E-mail: so_mohades@yahoo.com

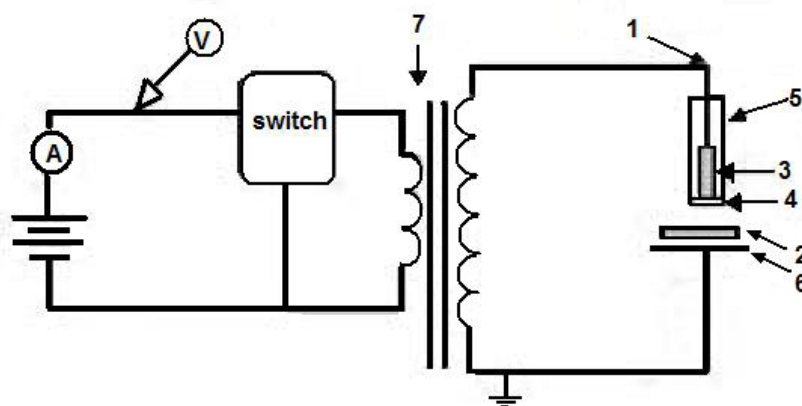

Figure 1: Schematic diagram of experimental set up; 1) high voltage electrode, 2) bacteria sample, 3) copper electrode, 4) quartz dielectric, 5) teflon cover, 6) ground electrode, and 7) high voltage transformer

toxic gasses. Radiation (*e.g.*, x-ray and γ -ray) has also some limitations mostly due to safety concerns [6]. It is shown that DBD plasma is effective in decontamination of microorganism *in vitro* and *in vivo* without any deleterious effects on living tissue [4].

Plasma, which is generated by breakdown in a working gas, contains electron, ions, reactive molecules, free radicals, and radiations. When a sample comes to contact with plasma, all these factors interact with the surface of the sample. Different studies tried to describe the kinetic of bacterial inactivation by plasma and proposed several mechanisms [8, 9]. These interpretations include:

1. Destruction of the genetic material of the microorganism by UV irradiation; UV radiation is known to cause lethal damage to cells. It can affect the bacteria through destruction and the dimerization of thymine bases in the bacterial DNA. This inhibits the ability of the bacteria to replicate properly [8, 10].

2. Reactive species in the plasma can erode the microorganism, atom by atom, through etching. Etching stems from the adsorption of reactive species in the plasma by the microorganism. It subsequently undergoes chemical reactions which ultimately lead to form volatile compounds. The reactive species at air plasma can be atomic and molecular radi-

cals such as O, O₂^{*}, O₃, OH, NO, NO₂, and ¹O₂ singlet state [8, 11].

3. Charged particles can play an important role in the destruction of the outer membrane of the bacterial cells. Charged particles that are accumulated on the outer surface of the cell membrane produce an electrostatic force that causes rupture of the membrane. In addition, bombardment of microorganisms by energetic charged particles like ions and electrons can result in the destruction of and physical damage to the bacterial cell wall [12, 13].

In this paper, we present an air DBD plasma generator working at atmospheric pressure and low temperature. The inactivation effect of this DBD plasma on *Bacillus subtilis*, a Gram-positive bacteria, at various exposure time and applied voltages is studied.

Materials and Methods

Sample preparation

B. subtilis samples were supplied by Department of Biology, Shahid Beheshti University. Single colonies were used to inoculate 5 mL of Lysogeny broth (LB) to be grown at 37 °C overnight, shaking at 230 rpm. The cell suspension was then centrifuged and the supernatant was removed. The pellet was resuspended in sterile phosphate-buffered saline (PBS) to



Figure 2: An image of the DBD plasma generated at 10 kV and 10 kHz

obtain a bacterial concentration of approximately 10^8 colony-forming units (CFU) as determined by 0.5 McFarland standard and spectrometer assays. Suspension with concentration of 10^7 CFU/mL was made; 200 μ L aliquots of the resuspended bacteria were spread on a sterile agar plates uniformly and were left to air dried in a laminar-flow hood before plasma treatment.

Experimental system

The plasma generator consisted of a high voltage copper rod electrode with an area of high voltage electrode of 154 mm² insulated by a Teflon cylinder, avoiding the electrical shock. A quartz plate with 1 mm thickness, as the dielectric barrier, was stuck to the high voltage electrode. The ground electrode was in front of the dielectric barrier where the bacteria plate was placed (Fig. 1).

DBD plasma was generated by applying high voltage sinusoidal wave to the upper electrode. The second electrode was grounded for the safety of the device. The applied voltage for this experiment was set to 10 kV. The frequency of the power supply was fixed at 10 kHz. The bacterial sample plates were placed between the two electrodes; the DBD probe was placed at a distance of 1 mm above the bacterial sample surface. In this case, uniform non-thermal plasma was generated between the surface of the agar gel and the dielectric. Figure 2 shows a cross section area of the DBD plasma generated at 10 kV.

DBD plasma is a non-thermal source of plasma and is known as “cold plasma.” To evaluate the thermal effect of the plasma on *B. subtilis* inactivation, the temperature of the sample was measured immediately after the treatment. We used a non-contact infrared thermometer (model AR882, Starmeter Instruments Co.) to measure the temperature of the treated samples. To increase the accuracy of the measurement, the sample plates were exposed to DBD plasma for 60 second at a voltage of 10 kV. Then, the temperature of the sample was measured by the thermometer

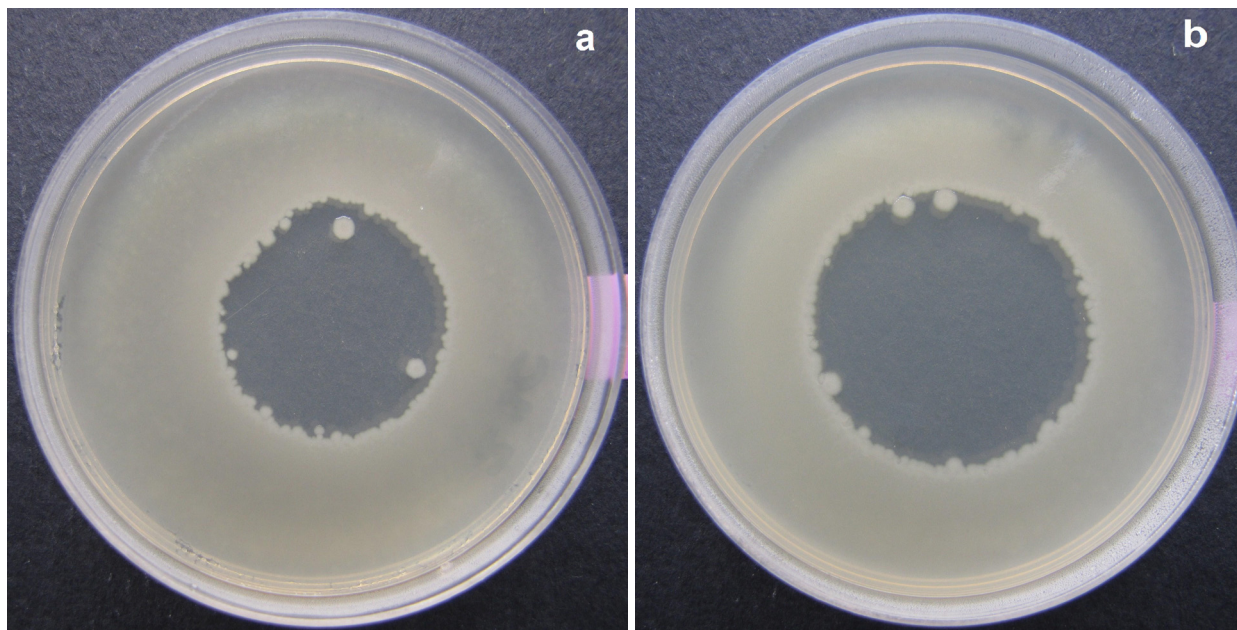

Figure 3: Two culture plates treated with DBD plasma at a voltage of 10 kV and frequency of 10 kHz for a) 5 sec and b) 20 sec.

immediately.

The bacterial samples were exposed to plasma for different exposure times. Then, the treated samples were incubated for 15 hours at 37 °C. Finally, the treated area was calculated by MATLAB image processing program.

Results

Figure 3 shows two culture plates exposed for 5 and 20 sec to DBD plasma produced with a voltage of 10 kV. The central zone shows where the treatment ceased bacterial growth. The opaque surrounding region is where bacteria could grow. The longer the treatment time, the larger was the decontaminated area.

Figure 4 presents the inactivated CFUs of *B. subtilis* after the treatment times of 5, 7, and 20 sec using an applied voltage of 10 kV. In all experiments, the frequency of the power supply was set at 10 kHz. With increasing the exposure time, the number of inactivated CFUs were increased. Furthermore, fast inactivation of the DBD plasma is Obvious. For 5 sec of treatment the cleaned area was larger than the plasma-surface interaction of 154 mm² (surface area of the high voltage electrode). This method had no thermal effect as measured sample temperatures did not exceed 39 °C.

Discussions

The plasma volume, which is generated between the dielectric, and the agar surface is confined to the area of the high voltage electrode. The electric field is also limited to this region which results in the presence of charged particles in this area. This area is known as the “plasma-surface interactions” [15]. Nonetheless, the reactive agents of the plasma, because of collisions, can diffuse out of the confined electric field to the adjacent region where the electric field strength is moderate, and react with the bacteria.

According to the decontaminated area, DBD plasma inactivation has two phases. During the first phase, the decontaminated area of the sample is confined to the diameter of

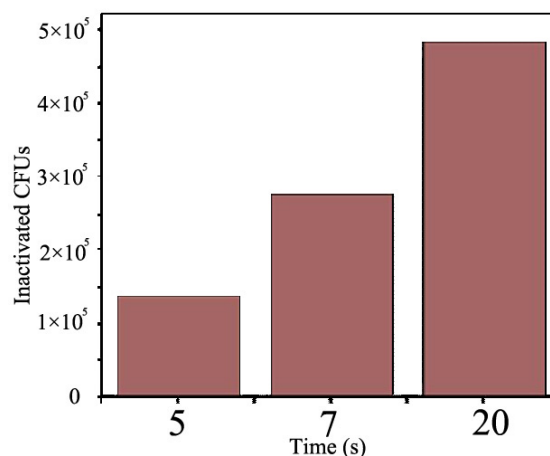

Figure 4: The inactivated CFUs of *B. subtilis* after various exposure times

high voltage electrode—the surface-plasma interaction. This phase occurs quickly, and for a voltage of 10 kV, complete inactivation is achieved within 5 sec. The second phase attributes to the diffusion of plasma particles; the inactivated area expands over the time up to a specific area which is determined by the plasma diffusion. While during the first phase the charged particles and reactive species are responsible for the decontamination, in the second phase, reactive species are mainly responsible for the surface inactivation.

Our results showed the high efficiency of DBD plasma generator for fast inactivation of Gram positive bacteria, *B. subtilis*. Considering the low temperature and non-destructive features of this method, it seems that this method is applicable for fast sterilization of resistant bacteria and hospital sensitive instruments.

References

1. Cheruthazhekatt S, Černák M, Slavíček P, Havel J. Gas plasmas and plasma modified materials in medicine. *J Appl Biomed* 2010;**8**(2):55-66.
2. Xu X. Dielectric barrier discharge- properties and applications. *Thin Solid Films* 2001;**390**:237-42.
3. Kogelschatz U, Eliasson B, Egli W. From ozone generators to flat television screens: history and future potential of dielectric-barrier discharges. *Pure Appl Chem* 1999;**71**(10):1819-28.
4. Stoffels E, Sakiyama Y, Graves D. Cold atmo-

- spheric plasma: charged species and their interactions with cells and tissues. *IEEE Trans Plasma Sci* 2008;**36**(4):1441-57.
5. Sun Y, Qiu Y, Nie A, Wang X. Experimental research on inactivation of bacteria by using dielectric barrier discharge. *IEEE Trans Plasma Sci* 2007;**35**(5):1496–1500.
 6. Ray C, Ryan Kenneth J. Sherris medical microbiology: An introduction to infectious diseases. 5th ed. New York: McGraw-Hill Medical; **2003**.
 7. Philip N, Saoudi B, Crevier M C, *et al*. The respective roles of UV photons and oxygen atoms in plasma sterilization at reduced gas pressure: The Case of N₂–O₂ Mixtures. *IEEE Trans Plasma Sci* 2002;**30**(4):1429-36.
 8. Moisan M, Barbeau J, Crevier M, *et al*. Plasma sterilization, Methods and mechanisms. *Pure Appl Chem* 2002;**74**(3):349-58.
 9. Laroussi M. Low-temperature plasmas for medicine. *IEEE Trans Plasma Sci* 2009;**37**(6):714-25.
 10. Laroussi M, Leipold F. Evaluation of the roles of reactive species, heat, and UV radiation in the inactivation of bacterial cells by air plasmas at atmospheric pressure. *Int J Mass Spectrom* 2004;**233**(1/3):81-6.
 11. Kogelschatz U, Eliasson B, Hirth M. Ozone generation from oxygen and air: discharge physics and reaction mechanisms. *Ozone Sci Eng* 1988;**10**:367-78.
 12. Laroussi M, Mendis D A, Rosenberg M. Plasma interaction with microbes. *New J Phys* 2003;**5**:41.1-41.10.
 13. Mendis D A, Rosenberg M, Azam F. A note on the possible electrostatic disruption of bacteria. *IEEE Trans Plasma Sci* 2000;**28**(4):1304-6.
 14. Kostov K G , Rocha V, Koga-Ito C Y, *et al*. Bacterial sterilization by a dielectric barrier discharge (DBD) in air. *Surf Coat Technol* 2010;**204**(18-19):2954-9.
 15. Laroussi M, Lu X. Room-temperature atmospheric pressure plasma plume for biomedical applications. *Appl Phys Lett* 2005;**87**(11):113902-4.